

VÁLVULA MARIPOSA LUG VF-011

MATERIALES ESTÁNDAR – PIEZAS PRINCIPALES

PART NAME	MATERIAL	ESPECIFICACIÓN
CUERPO	FUNDICIÓN DÚCTIL	EN-JL1040
EJE	ACERO INOXIDABLE	BS970 420S37
DISCO	ACERO INOXIDABLE	BS970 304S15
	BRONCE	EN1982 CC491K
	HIERRO DÚCTIL CROMADO O RECUBRIMIENTO FBE	EN-JS1050
COJINETE	PTFE	COMERCIAL
ANILLO	EPDM/NBR/VITON	COMERCIAL

ESPECIFICACIONES

ESTÁNDAR	EN593	
BRIDA SUPERIOR	ISO5211/1	
TIPO DE BRIDA	EN1092-2 PN10/PN16/PN25	
ACCIONAMIENTO	MANUAL O ENGRANAJE	
WORKING PRESSURE	50 A 600	PN16/CLASS125
	50 A 300	PN20/CLASS150
	50 A 300	PN25/CLASS250

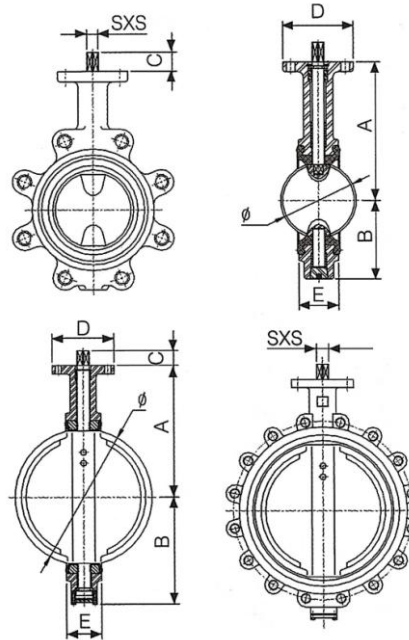
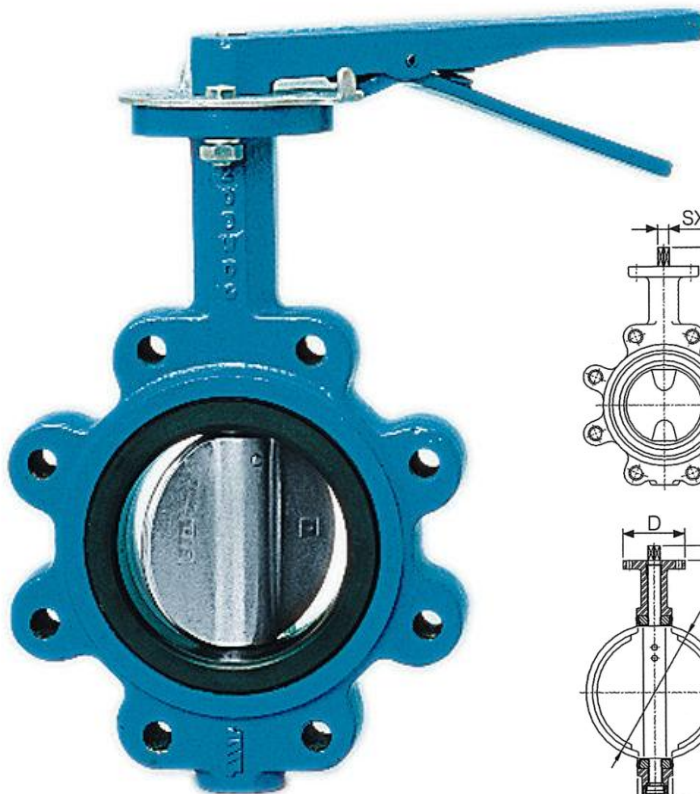

Tamaño 50-300

Tamaño 350-600

TAMAÑO	50	65	80	100	125	150	200	250	300	350	400	450	500	600
A	140	152	160	180	191	202	241	274	315	368	400	422	480	562
B	68	76	85	100	120	132	160	200	230	280	310	340	388	450
C	30	30	30	30	30	30	30	30	30	45	45	45	45	45
D	90	90	90	90	90	90	125	125	125	150	175	175	210	210
E	43	45	46	51.5	56	56.5	68.5	68.5	79.5	78	88	109	127	154
Ø	56.8	71.5	83	101.5	127.8	151.1	251.3	251.3	300.5	335.5	393.5	443.5	500.5	600.8
SxS	11 x 11		14 x 14			17 x 17		22 x 22			27 x 27		Ø48	

