

DOUBLE ECCENTRIC BUTTERFLY VALVE PN16-PN25 VF-012

STANDARD MATERIAL – MAIN PARTS

ITEM	NAME	MATERIAL
1	COVER	A105
2	BODY	DUCTILE IRON / GGG50
3	SEAT RING	SS304
4	SEAL RING	EPDM
5	DISC	DUCTILE IRON / GGG50
6	PIN	SS304
7	STEM	SS410
8	RETAINER FLANGE	DUCTILE IRON / GGG50
9	BUSHING	B148
10	PACKING	GRAPHITE

SPECIFICATIONS

FACE TO FACE	DIN3202, F4 (UNE EN 558-1)
WORKING PRESSURE	PN16-PN25
RANGE OF APPLICATION	DN50 – DN2400
COATING	EPOXY
RANGE OF USE	FOR DRINKING WATER

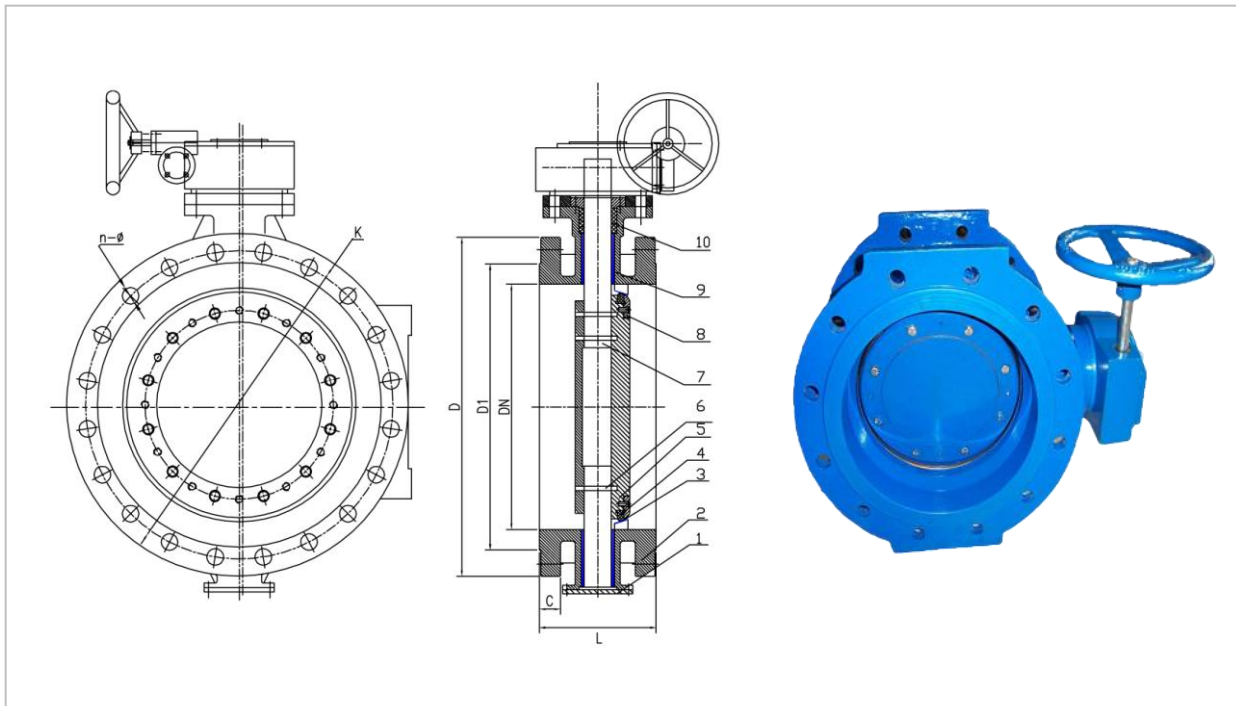

DN	PN	Ø D	Ø D1	L	K	C	n-Ø
100	16	220	156	190	180	19	8-Ø19
125	16	250	184	200	210	19	8-Ø19
150	16	285	211	210	240	19	8-Ø23
200	16	340	266	230	295	20	12-Ø23
250	16	405	319	250	355	22	12-Ø28
300	16	460	370	270	410	24.5	12-Ø28
350	16	520	429	290	470	26.5	16-Ø28
400	16	580	480	310	525	28	16-Ø31
450	16	640	548	330	585	30	20-Ø31
500	16	715	609	350	650	31.5	20-Ø34
600	16	840	720	390	770	36	20-Ø37
700	16	910	794	430	840	39.5	24-Ø37

DN	PN	Ø D	Ø D1	L	K	C	n-Ø
800	16	1025	901	470	950	43	24-Ø41
900	16	1125	1001	510	1050	46.5	28-Ø41
1000	16	1255	1112	550	1170	50	28-Ø44
1100	16	1355	1218	590	1270	53.5	32-Ø44
1200	16	1485	1328	630	1390	57	32-Ø50
1400	16	1685	1530	710	1590	60	36-Ø50
1500	16	1820	1640	750	1710	62.5	36-Ø57
1600	16	1930	1750	790	1820	65	40-Ø57
1800	16	2130	1950	870	2020	70	44-Ø57
2000	16	2345	2150	950	2230	75	48-Ø62
2200	16	2535	2360	1030	2430	80	52-Ø62
2400	16	2745	2570	1110	2640	85	56-Ø62

